

Computer Controlled
PAN-TILT UNIT

Model PTU-D300

USER'S MANUAL

Version 2.18.0

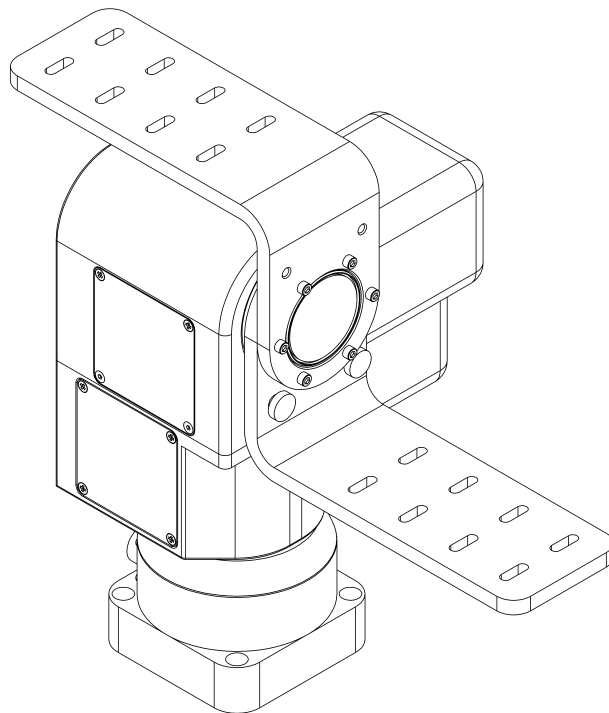

Pan-Tilt Unit (Model PTU-D300) User's Manual, Version 2.18.0,
October 24, 2006

©1991,2006, 2009 by Directed Perception, Inc., 890C Cowan
Road, Burlingame, California 94010, (650)692-3900, FAX:
(650)692-3930, www.DPerception.com.

All rights reserved. Protected under numerous U.S. Patents including 5463432 and 5802412, and patents pending. No part of this book may be reproduced, stored in a retrieval system, or transcribed, in any form or by any means, electronic, mechanical, photocopying, recording, or otherwise, without the prior written permission of Directed Perception, Inc.

The information in this manual is subject to change without notice and, except for the warranty, does not represent a commitment on the part of Directed Perception. Directed Perception cannot be held liable for any mistakes in this manual and reserves the right to make changes.

1	INTRODUCTION	1
1.1	IMPORTANT SAFEGUARDS AND WARNINGS.....	2
1.2	Models	2
2	QUICK START	3
2.1	Overview.....	3
2.2	Installation Components	3
2.3	Basic Setup Steps	4
3	INSTALLATION & INITIAL SETUP	5
3.1	Pan-Tilt Mounting.....	5
3.2	Wiring and Connectors	5
3.3	Power Sources.....	6
3.4	RS-232 Interface and Host Settings.....	7
3.5	Initial Power-up and Test	8
3.6	Basic Pan-Tilt Unit Commands	8
3.7	Mounting Your Payload.....	8
	3.7.1 Over-the-Top Bracket Mounting.....	9
	3.7.2 Side-Mount Bracket Mounting.....	9
3.8	Payload Wiring Connections	10
4	COMMAND REFERENCE.....	11
4.1	Binary Command Format	11
4.2	General ASCII Command Format	11
4.3	Positional Control Commands & Queries	11
	4.3.1 Position (absolute)	11
	4.3.2 Offset Position (relative offset).....	12
	4.3.3 Resolution per Position.....	12
	4.3.4 Limit Position Queries	13
	4.3.5 Position Limit Enforcement.....	13
	4.3.6 Immediate Position Execution Mode.....	14
	4.3.7 Slaved Position Execution Mode.....	14
	4.3.8 Await Position Command Completion	15
	4.3.9 Halt Command.....	15
	4.3.10 Monitor (Autoscan) Command.....	16
	4.3.11 Position Presets	16
4.4	Speed Control Commands & Queries.....	17
	4.4.1 Speed Control & Relevant Terms	17
	4.4.2 Speed (absolute).....	17
	4.4.3 Delta Speed (relative offset)	18
	4.4.4 Acceleration	19
	4.4.5 Base (Start-Up) Speed.....	19
	4.4.6 Speed Bounds	20
	4.4.7 Speed Control Modes.....	20
4.5	Unit Commands	21

4.5.1	Reset Pan-Tilt Unit	21
4.5.2	Default Save/Restore	22
4.5.3	Echo Query/Enable/Disable.....	22
4.5.4	Feedback Verbose/Terse/Off.....	23
4.5.5	Controller Firmware Version Query	23
4.5.6	Outside Supply Voltage and Controller Temperature Query	23
4.6	Power Control Commands & Queries	23
4.6.1	Stationary Power Mode.....	24
4.6.2	In-Motion Power Mode	24
4.7	Host Serial Port and Control.....	25
4.7.1	Configuring Host Serial Port Baud and Communications.....	25
4.8	Step Modes.....	26
4.8.1	Configuring Step Mode.....	26
5	SPECIAL CONFIGURATIONS	27
5.1	High-Speed Operation	27
5.2	High-Payload Operation	27
5.3	Battery-Powered Operation	27
6	PTU OPTIONS.....	28
6.1	EIO Option: Expansion Serial Ports and Control	28
7	NETWORKING.....	28
7.1	Basic Networking Setup Steps.....	28
7.2	PTU Network Connections	29
7.3	PTU Network Software Commands	29
7.3.1	Unit Network ID	29
7.3.2	Unit Select/Deselect.....	30
A.	SPECIFICATIONS.....	31
A.1	D300 Mechanical Dimensions.....	31
A.2	D300 Payload Bracket Dimensions	32
A.3	D300 Base Connector Wiring.....	33
A.4	D300 Payload Wiring PL01	34
A.5	D300 Payload Wiring PL02.....	35
A.6	D300 Payload Mounting.....	36
	REGULATORY INFORMATION.....	37
	LIMITED WARRANTY	38

1 INTRODUCTION

The PTU-D300 Pan-Tilt Unit from Directed Perception provides fast, accurate, and durable positioning of cameras, antennas, lasers, and other large payloads. Some general features:

- Simple to command from any RS-232 or RS-485 terminal or computer
- Payload capacity up to 35-70 lbs.
- Resolution of 0.02 degrees
- Precise control of position, speed & acceleration
- On-the-fly position and speed changes
- Self calibration upon reset
- Power consumption can be controlled from host
- ASCII command mode for simplicity, binary commands available for efficient program control
- Constant current DMOS motor drives for increased performance and control
- DC power input from an unregulated source
- Flexible connectivity options.

Applications of the PTU-D300 include:

- Mid and Long-range Surveillance systems
- Automated detection and tracking
- Multi-sensor perimeter monitoring systems
- Thermal and IR cameras
- Marine/shipboard sensor systems
- Harbor and Port Security
- Border Security & Law Enforcement
- Highway & Transportation Monitoring
- Military special operations
- Satellite communications systems
- Microwave antenna systems (passive, active)
- Robotics & computer vision.

This User's Manual provides information needed to set up and operate the PTU-D300 unit. The next section provides a brief overview to allow you to get started as quickly as possible. More detailed technical information is provided in the remaining sections.

1.1 IMPORTANT SAFEGUARDS AND WARNINGS

IMPORTANT SAFEGUARDS AND WARNINGS

1. Please read these instructions prior to use.
2. Please keep these instructions accessible.
3. Please heed all warnings.
4. Please follow all instructions.
5. Installation should be done only by qualified personnel and conform to all local codes.
CAUTION: These servicing instructions are for use by qualified service personnel only.
To reduce the risk of electric shock, do not perform any servicing other than that contained in the operating instructions unless you are qualified to do so.
6. Use only mounting methods and materials capable of supporting at least four times the combined weight of the D300 pan-tilt, mounted payloads, and cabling.
7. For outdoor use, use only corrosion resistant hardware to fasten the mount and payloads (e.g., stainless steel screws).
8. The unit should not be installed in environments that present conditions beyond the environmental specification of the D300. Installation near heat sources such as radiators, heat registers, stoves, or other apparatus (including amplifiers) can exceed the unit's temperature ratings.
9. Refer all servicing to qualified service personnel. If the unit is damaged, remove power immediately, and contact Directed Perception.
10. A readily accessible power disconnect shall be incorporated into the installation wiring.
11. Only use replacement parts recommended by Directed Perception.

1.2 Models

PTU-D300	Standard base configuration. Includes basic slip-ring, integral controller, standard convertible "L" bracket.
----------	---

2 QUICK START

2.1 Overview

Figure 1 shows a system overview. The PTU-D300 includes an integral controller and it accepts control commands from any host computer over RS-232 or RS-485. The basic D300 connections are: D300-power from a DC power source, and Pan-Tilt Control via RS232/485.

In addition to pan-tilt control connections, "Payload Pass-Thru" internally routes payload signals such as video, payload power, and other payload connections from a single stationary connector in the PTU base to a single payload connector that moves with your payload.

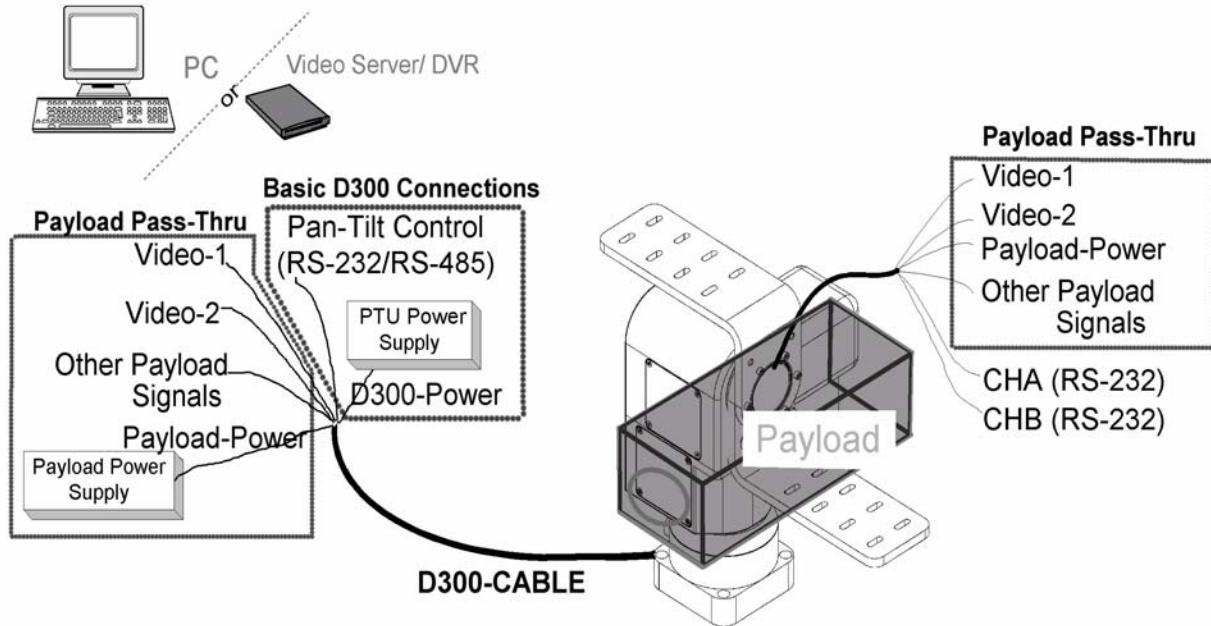

Figure 1: Pan-Tilt System Overview

The PTU-D300 can be controlled from any host computer using the built-in ASCII protocol described in this manual. For high speed, hard real-time controls (such as tracking), a binary protocol is supported via a C Programmers Interface (PTU-CPI). Drivers are also available in 3rd party software packages such as LabView and digital video control systems.

2.2 Installation Components

Components supplied with this manual are:

- Pan-Tilt Unit
- Standard Payload Mounting Bracket
- Pan-Tilt Cable Harness - Optional
- AC/DC Power Supply - Optional

2.3 Basic Setup Steps

The following outlines the basic pan-tilt set-up and installation steps. Section 3 details each of these steps.

1. Unpack the D300 pan-tilt. Mount the pan-tilt securely. See section 3.1 for details on mounting.
2. Establish wiring to the pan-tilt. Factory cable with breakouts for power and other connections makes this easy (model D300AC-CABLE). Or you can make your own cables that better suit your installation.
3. Connect an RS-232 or RS-485 cable between Pan-Tilt Control input and a host computer. When using factory cable D300AC-CABLE, standard RS232 connection (DB9F) is provided. HyperTerminal (built into Windows) is the most commonly used comm program. Communications parameters are: 9600 baud, no parity, no handshaking. (see Section 3.4).
4. Provide DC power to the pan-tilt. When using factory cable D300AC-CABLE, easy plug-in power is provided by AC/DC power supply model D300AC-APS-30V. Or you can obtain your own DC power source that better suits your installation.
5. Power up the pan-tilt. If power is working, the unit will go through a power-up calibration. At power up, the pan-tilt defaults to providing splash text on your terminal that will identify the unit configuration. Pan-tilt operation can then be tested by typing commands into your terminal program.
6. Section 3.6 describes some basic pan-tilt commands to get you going. Section 4 provides a full description of all pan-tilt unit commands and queries.
7. You can now mount and wire your payload (e.g., camera) on the pan-tilt unit (see Section 3.8).

3 INSTALLATION & INITIAL SETUP

This section describes the basic installation and setup steps required to get your pan-tilt operational as quickly as possible.

3.1 Pan-Tilt Mounting

Appendix 1 shows the mounting pattern for the PTU-D300. The basic mounting pattern is four #1/4-20 socket-head cap screws in a 3.375" (85.725mm) square pattern. All four mounting screws should be used. The mount strength must be able to hold the weight of the unit plus the payload plus any additional forces exerted on the system (*e.g.*, wind, G forces). A good rule of thumb: the mount must support at least four times the combined weight of the payload plus the weight of the pan-tilt (*e.g.*, a 25 lb. payload mounted to the D300 must support at least 205 lbs).



CAUTION: FAILURE TO SECURE THE PAN-TILT AND ITS PAYLOAD TO A SUFFICIENTLY STRONG MOUNTING CAN RESULT IN DAMAGE TO THE PAN-TILT, THE PAYLOAD, OR POSSIBLE INJURY OR DEATH. YOU MUST ENSURE THE MOUNTING IS CAPABLE OF HOLDING THE LOADS!

3.2 Wiring and Connectors

Figure 2 shows a back view of the D300. The D300 *base connector* is a MIL-C-26482 compatible receptacle (19 pins). Appendix A.3 shows the D300 *base connector* signals and wiring. Basic control requires that you connect a DC power source to the D300-power input, and a host computer connection (to HOST-232 *or* HOST-485) to communicate and control the D300.

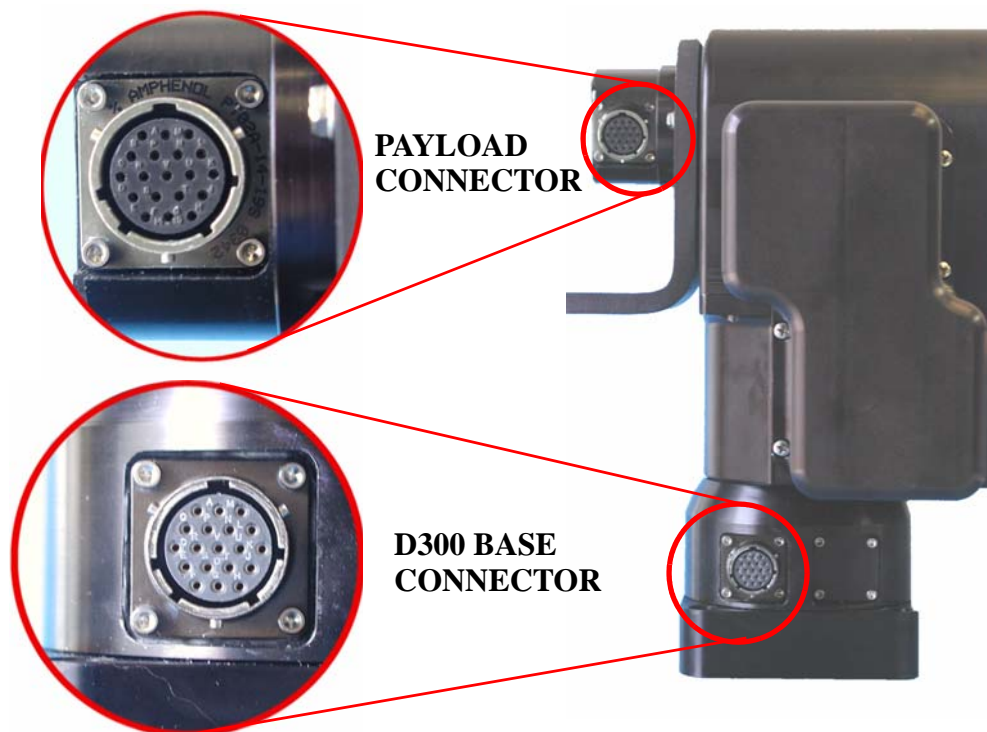

Figure 2: Wiring Overview

The easiest way to wire into the D300 is to use the DP factory cable with breakouts for power and other connections (model D300AC-CAB-25BO), and to use the DP factory power supply (model D300AC-APS-30V). This allows you to plug in and run the D300 in minutes. Or you can use the wiring diagram in Appendix A.3 to make your own cables that better suit your installation.

Connect an RS-232 or RS-485 cable between the D300 and a host computer. When using the factory cable D300AC-CAB-25BO, standard RS232 connection (DB9F) is provided. HyperTerminal (built into Windows) is the most commonly used communications program. Communications parameters are: 9600 baud, no parity, no handshaking. (see Section 3.4).

The D300 provides *payload pass-thru* signals that connect between pins in the *base connector* to corresponding pins in the *payload connector*. Additional pins in the payload connector provide other payload controls (auxiliary RS232 ports and TTL control). Figure 2 shows this *payload connector* which is also a MIL-C-26482 compatible receptacle (19 pins). Appendix A.4 details the payload connector pin-out.

Appendix A.4 shows the payload connector wiring. Pins highlighted in red indicate payload pass-thru signals connected to corresponding pins in the base connector.

When attaching payload signals to the system, care must be taken to adhere to all specifications for the pass-thru signals, such as maximum voltage and current levels.



3.3 Power Sources

The PTU-D300 requires a 9-30VDC (unregulated) power source capable of 2.25A peak. Less peak current is required if you do not use the higher motor current controls available (see Sections 4.6.1 and 4.6.2). To achieve the highest pan-tilt unit performance, use the highest motor voltage within the allowable range. To achieve the quietest and smoothest pan-tilt operation, you can use a lower motor voltage (*e.g.*, 12VDC).

When wiring your own power source, failure to comply with wiring and power source requirements described in this manual can result in decreased unit performance or damage not covered under the limited warranty.



If you are providing your own DC power source, the power source must never supply more than rated current, and if so, you must add a fuse in series with your DC power source. For example, when connecting to a vehicle battery or lighter plug, you must fuse the incoming DC source. Failure to properly fuse your input power source could cause overloading of internal protection devices, pose a safety hazard, or void product warranties.

3.4 RS-232 Interface and Host Settings

An RS-232 terminal or host computer connects to the RS-232 Host Interface on the Pan-Tilt Unit. The host terminal or computer should be set to 9600 baud, 1 start bit, 8 data bits, 1 stop bit, and no parity. Hardware handshaking and XON/XOFF are not used.

The RS-232 connections to the Pan-Tilt are: TxD (pin 2), RxD (pin 3), and GND (pin 5). Figure 3 shows cable configurations for some common computer hosts. Since TxD and RxD assignments to pins 2 and 3 can vary on host computers, try using a null modem if your initial connection does not work.

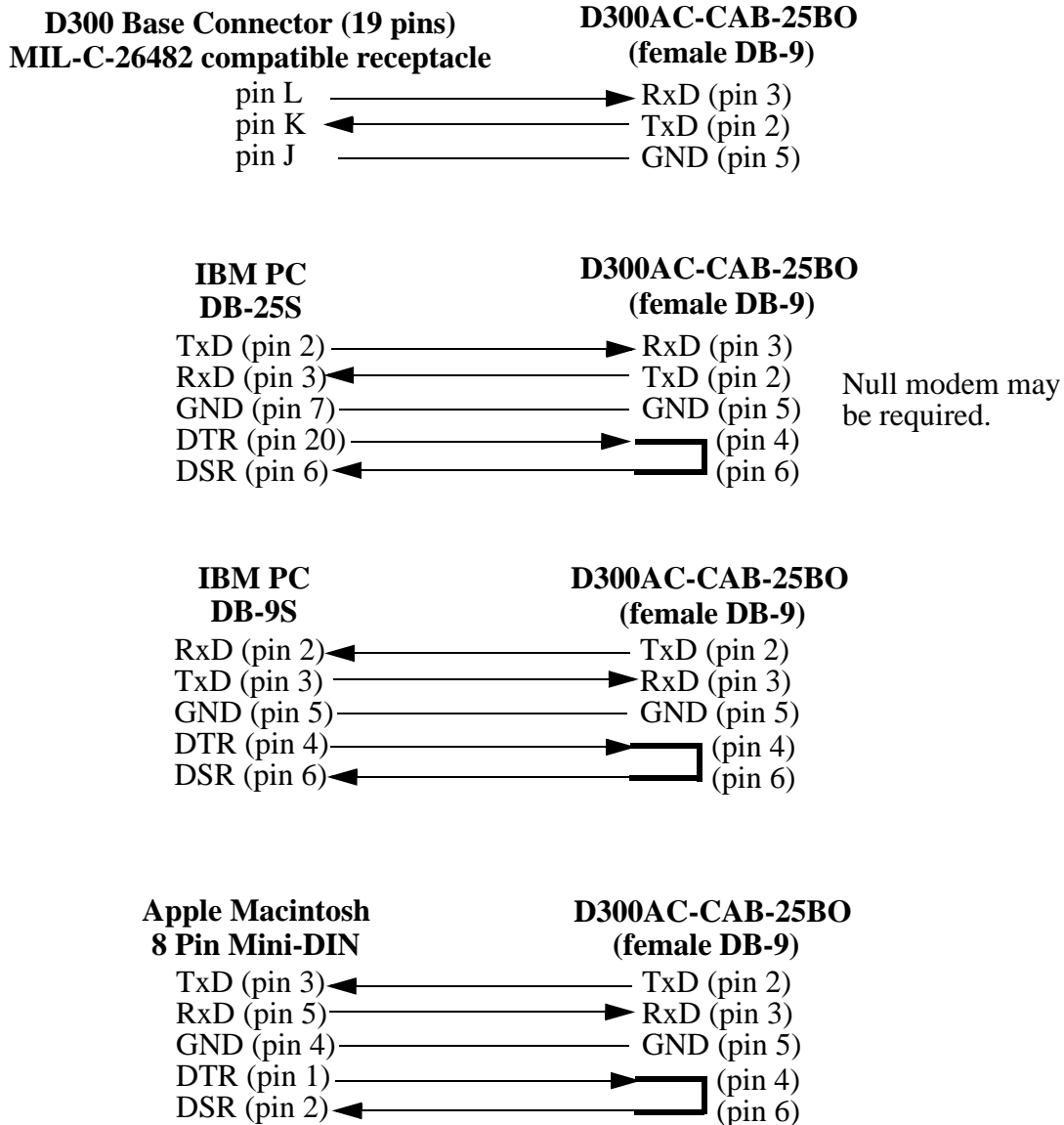

Figure 3: RS-232 Pan-Tilt Controller Connection to Common Hosts

3.5 Initial Power-up and Test

If you have the power source and Host computer connected described in Sections 3.3 and 3.4, you are ready to power-up and test its operation. Test and verify all cable connections and connector wiring before power-up. We suggest that you do not mount your payload (e.g., camera) until this initial installation is completed and tested.

1. Using HyperTerminal or a similar terminal program, configure the RS-232/485 serial port of the Host Computer to 9600 baud, 1 start bit, 8 data bits, 1 stop bit, and no parity. Hardware handshaking and XON/XOFF are not used.
2. You are now ready to power up the pan-tilt unit and test its operation. Apply power. Upon power up, introduction text should appear on your screen, and the pan-tilt unit should go through a reset cycle (pan and tilt axes will cycle through their full range of motion). This reset is completed when an asterisk ('*') appears. If the unit did not reset properly, recheck your power source and cabling. If the unit went through its reset procedure, but no text or garbled text appears on your screen, then:
 - Check that the host RS-232/RS-485 host port settings are correct (see Section 3.4)
 - Check that the RS-232/RS-485 cable is correct for your host (see Section 3.4)
3. You are now connected to the pan-tilt. Enter the character '?' for a complete listing of commands. The next section describes some basic commands to help you get going, and a full command description may be found in Section 4. We suggest that you exercise the unit and become familiar with its operation and commands before mounting your payload (e.g., camera) as described in Section 3.8. Special attention should be paid to acceleration and speed commands, and they should be set at levels appropriate to your payload weight and size.

3.6 Basic Pan-Tilt Unit Commands

Below are some pan-tilt commands that will familiarize you with the pan-tilt unit and its operation:

```
pp2500 *
tp-900 *
PS1900 *
pp0 *
```

This sets the pan axis to position 2500, the tilt axis to position -900, the pan speed to 2500 positions a second, and sets the pan position back home.

When operating the pan-tilt unit, the available command menu is printed when you enter the '?' character. A detailed description of pan-tilt commands and queries may be found in Section 4.

3.7 Mounting Your Payload

The PTU-D300 sports a flexible payload bracket system that can be configured in a number of ways to support a variety of payloads including cameras, lasers, antennas, and other equipment. Because of the heavy payload weights and high potential speeds supported by the PTU-D300, it is very important that all guidance and instructions regarding payload mounting be followed carefully.

3.7.1 Over-the-Top Bracket Mounting

1. Ensure the pan-tilt has been through its calibration (at power up) so that the mounting hub is in a known home position.
2. Orient the bracket so the horizontal part of the bracket is topmost. When in the proper orientation, a peg in the bracket will locate into a hole in the D300 mounting hub.
3. Attach the bracket using 6pcs screws.



It is vital that thread lock is used for the bracket mounting screws. The thread holes in the hub have thread lock applied to them. If the bracket is removed, you should apply medium strength thread lock to the hub (e.g., Loctite 242).

4. Reset the pan-tilt and ensure that the bracket moves properly through its range of motion.

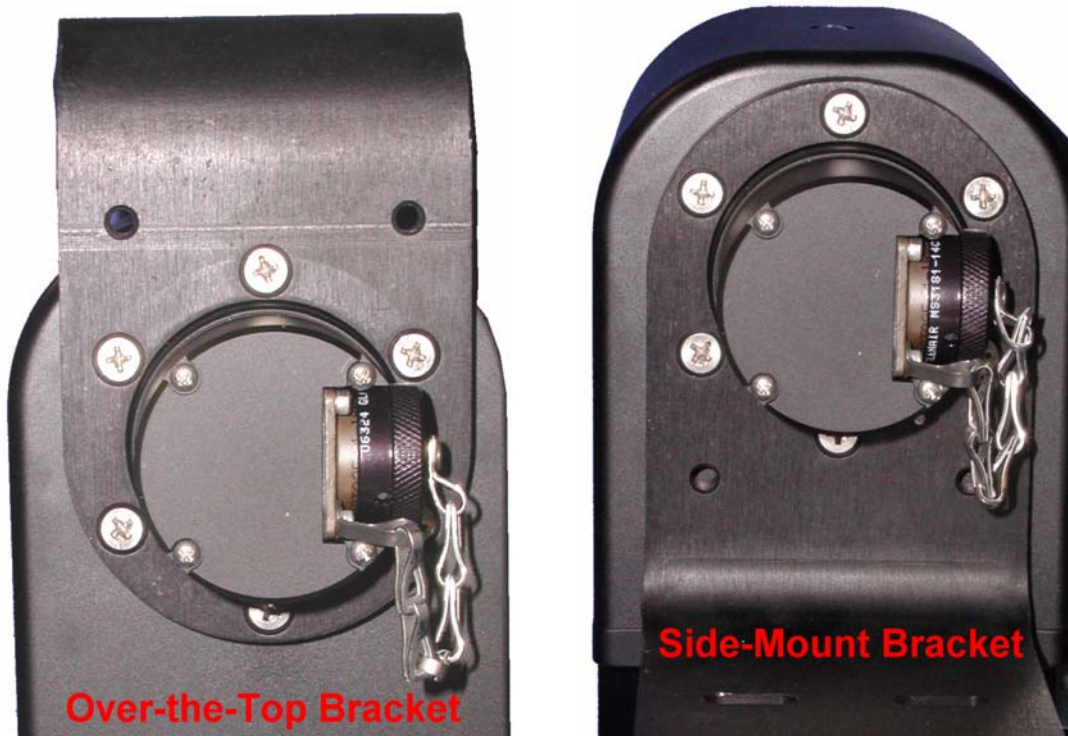

Figure 4: Payload Bracket Mounting

3.7.2 Side-Mount Bracket Mounting

1. Ensure the pan-tilt has been through its calibration (at power up) so that the mounting hub is in a known home position.
2. Orient the bracket so the horizontal part of the bracket is bottommost.
3. Attach the bracket using 6pcs screws.



It is vital that thread lock is used for the bracket mounting screws. The thread holes in the hub have thread lock applied to them. If the bracket is removed, you should apply medium strength thread lock to the hub (e.g., Loctite 242).

4. Reset the pan-tilt and ensure that the bracket moves properly through its range of motion.

Payloads should be mounted as close to the Pan-tilt housing as possible so as to position the center of gravity as close to the pan-axis as possible.



In all cases, care must be taken to ensure that the payload will clear the Pan-tilt housing *and* surrounding objects throughout the full range of motion of the unit.

Though the PTU-D300 unit is rated to a maximum load of 70 lbs, the distribution of the load affects the actual load capable of being moved by the pan-tilt unit. The steps to determine whether your load and its positioning (*e.g.*, center of gravity) are within the maximum load capacity and dynamics are:

- Mount your payload. Side-mount is preferred for heavier loads, as it keeps the payload center of gravity closer to the tilt axis of rotation thereby minimizing torque requirements. Ensure that the load is securely attached to the payload bracket.
- First move the pan axis through its range to test whether the pan-tilt can handle the load (*e.g.*, enter “**dr pp2700 a pp-2700 a pp0** ”). A load that is too heavy or moved too quickly will cause the unit to lose synchrony, and this will be accompanied by an audible “rrrr” sound from the pan-tilt unit motors. See section 5.2 on page 27 for further information on configuration of the Pan-Tilt for heavier payloads.
- If your load passed the pan axis load test, you can then test the tilt axis load handling capability. The center of gravity for top mounted payloads is further from the tilt axis of rotation, and this may require more torque to move the load. Move the tilt axis through its range of motion to test whether the pan-tilt can handle the load (*e.g.*, enter “**DR TP-900 A TP600 A TPp0** “). A load that is too heavy or moved too quickly will cause the unit to lose synchrony, and this will be accompanied by an audible “rrrr” sound from the pan-tilt unit motors.
- If your load fails the above pan or tilt axis load handling tests, check Section 5.2 for further information. Significantly faster or lower power control can be obtained via commands to the pan-tilt unit. The speed and acceleration of a mechanical system depends upon the inertial properties of your load. The ability of the pan-tilt unit to successfully move your load without losing synchrony depends upon the inertial load factors and their relationship to power supply voltage, unit speed, acceleration, position, motor torque, etc. Section 5.2 discusses how to configure pan-tilt parameters to achieve more optimal pan-tilt unit performance for your load. If you have questions about your payload mounting or load handling, please contact Technical Support for further assistance.
- If your load passes the above pan and tilt axis load handling tests, you are ready to begin controlling your load using the commands described in Section 4.

3.8 Payload Wiring Connections

The D300 provides *payload pass-thru* signals that connect between pins in the *base connector* to corresponding pins in the *payload connector*. Additional pins in the payload connector provide other payload controls (auxiliary RS232 ports and TTL control). Figure 2 shows this *payload connector* which is also a MIL-C-26482 compatible receptacle (19 pins). Appendix A.4 details the payload connector pin-out. Your payload connects to the payload connector via a male MIL-C-26482 compatible plug (*e.g.*, PT06A14-19P).

Appendix A.4 shows the payload connector wiring. Pins highlighted in red indicate payload pass-thru signals connected to corresponding pins in the base connector.



When attaching payload signals to the system, care must be taken to adhere to all specifications for the pass-thru signals, such as maximum voltage and current levels.

4 COMMAND REFERENCE

This section describes the pan-tilt unit command set. Each command has a section that provides a brief functional description, a format (syntax) description, examples, and related topics. When controlling the pan-tilt unit from a terminal, a complete menu of pan-tilt commands can be obtained by entering the character “?”.

4.1 Binary Command Format

A C Programmer's Interface (model PTU-CPI) is available for higher bandwidth binary communications between a host computer and the PTU controller.

4.2 General ASCII Command Format

When describing the format (syntax) of pan-tilt commands, the following conventions are adopted:

- Commands issued to the pan-tilt unit (e.g., typed in by you) are shown in bold.
- Input characters may be in upper or lower case (we show them in upper case for presentational consistency)
- A delimiter (<delim>) can be either a space (“ ”) or a carriage return (<CR>).
- A successfully executed command returns “*<CR>”. Successful query execution returns “* <QueryResult><CR>”. Command execution failure returns “! <ErrorMessage><CR>”. A pan axis limit hit asynchronously returns “!P” and a tilt axis limit hit asynchronously returns “!T”.

4.3 Positional Control Commands & Queries

4.3.1 Position (absolute)

Description:

Specify or query the absolute pan or tilt axis position. Desired positions can be changed on-the-fly without waiting for previous position commands to complete.

Syntax

Query current absolute pan position:	PP<delim>
Set desired absolute pan position:	PP<position><delim>
Query current absolute tilt position:	TP<delim>
Set desired absolute tilt position:	TP<position><delim>

Example

The following sends the pan axis to the left, waits, then sends it to the right:

```

PP-2500 *
A *
PP * Current Pan position is -2500
PP2500 *
A *
PP * Current Pan position is 2500

```

Related Topics

- Position (relative offset and desired position queries): See Section 4.3.2
- Position resolution (units): See Section 4.3.3
- Position limits: See Section 4.3.4
- Position execution modes: See Sections 4.3.6, 4.3.7 and 4.3.8
- Position limit enforcement modes: See Section 4.3.5

4.3.2 Offset Position (relative offset)

Description

Specify desired axis position as an offset from the current position, or Query the current axis position. Desired offset positions can be changed on-the-fly without waiting for previous position commands to complete.

Syntax

Query desired pan position: **PO<delim>**
 Set desired offset pan position: **PO<position><delim>**
 Query desired tilt position: **TO<delim>**
 Set desired offset tilt position: **TO<position><delim>**

Example

The following sends the pan axis to position -500, then sends it 1500 positions to the left:

```
PP-500 *
A *
PO * Current Pan position is -500
PO1500 *
A *
PP * Current Pan position is 1000
```

Related Topics

- Position resolution (units): See Section 4.3.3
- Position limits: See Section 4.3.4
- Position execution modes: See Sections 4.3.6, 4.3.7 and 4.3.8
- Position limit enforcement modes: See Section 4.3.5

4.3.3 Resolution per Position

Description

Query returns the axis resolution per position moved (in seconds/arc).

Syntax

Query pan resolution: **PR<delim>**
 Query tilt resolution: **TR<delim>**

Example

Resolution can be determined by:

```
PR * 92.5714 seconds arc per position
1 sec arc = 1/(60 min arc * 60 sec arc) = .0002778°. So 92.5714 seconds
arc equals (92.5714 sec arc * .002778°) = 0.025716335°. Thus, to pan 21.3°
left requires a relative move of (21.3°/0.025716°) ≈ 828 positions, yielding
the following command:
```

```
PO828 *
```

Related Topics

- Factory options are available to achieve higher resolution or accuracy.

4.3.4 Limit Position Queries

Description

Queries return the axis position bounds determined upon unit reset.

Syntax

```
Query minimum pan position:  PN<delim>
Query maximum pan position: PX<delim>
Query minimum tilt position: TN<delim>
Query maximum tilt position: TX<delim>
```

Example

```
R *
PN * Minimum Pan position is -3090
PX * Maximum Pan position is 3090
TN * Minimum Tilt position is -907
TX * Maximum Tilt position is 604
LE *
PP3200 ! Maximum allowable Pan position is 3090
```

Related Topics

- Position resolution (units): See Section 4.3.3
- Achieving larger axis bounds: See Section 4.3.5

4.3.5 Position Limit Enforcement

Description

Determines whether position commands beyond the detected pan axis limits are allowable. The default is pan position limits are enabled (*i.e.*, enforced).

When limits are enabled, commands outside of the limits return an error message and are not executed. In enabled limit mode, limits are only reached when the unit has lost synchrony and this error condition requires a unit reset (see Section 4.5.1). When a limit is reached, a “!P” is printed to the host serial port to indicate that the pan axis limit was hit.

When larger operational pan ranges are required, the limits may be disabled. Positional pan commands outside the limits are not rejected when limits are disabled.

Syntax

```
Query current pan position limit mode:  L<delim>
Enable pan position limits:            LE<delim>
Disable pan position limits:           LD<delim>
```

Example

```
L * Limit bounds are ENABLED (soft limits enabled)
PX * Maximum Pan position is 3090
PP3200 ! Maximum allowable Pan position is 3090
LD *
PP3200 *
A *
PP * Current Pan position is 3200
```

Related Topics

- Position commands: See Sections 4.3.1 and 4.3.2

4.3.6 Immediate Position Execution Mode

Description

Instructs pan-tilt unit to immediately execute positional commands. This is the default mode.

Syntax

I<delim>

Example

For the below commands, the pan axis will immediately execute the pan position command:

```
I *
PP1000 *
```

Related Topics

- Alternative slaved position execution mode: See Section 4.3.7

4.3.7 Slaved Position Execution Mode

Description

Instructs pan-tilt unit to execute positional commands only when an Await Position Command Completion command is executed (see Section 4.3.8) or when put into Immediate Execution Mode (see Section 4.3.6). This mode is useful when coordinated pan and tilt axis movements are desired.

Syntax

S<delim>

Example

The following commands change the position execution mode, instruct the axes which position to achieve, and an await command causes the position commands to be executed simultaneously:

```
DR *
S *
PP1500 *
TP-900 *
PP * Current Pan position is 0
TP * Current Tilt position is 0
A *
PP * Current Pan position is 1500
TP * Current Tilt position is -900
```

Related Topics

- Alternative immediate position execution mode: See Section 4.3.6

4.3.8 Await Position Command Completion

Description

Awaits the completion of the last issued pan and tilt axis position commands. Used to coordinate axis motions.

Syntax

A<delim>

Example

The following commands instruct the pan axis to move to a position, then move to another position:

```
I *
PP * Current Pan position is 0
PP2000 *
A *
PP * Current Pan position is 2000
PP0 *
A *
PP * Current Pan position is 0
```

In contrast, the following commands would begin to move to the first position, and before that position is reached, the next position would be moved towards (this is often called an on-the-fly position change):

```
I *
PP * Current Pan position is 0
PP2000 *
PP0 *
```

Related Topics

- This command can be used for both the Immediate Position Execution Mode (see Section 4.3.6) and Slaved Position Execution Mode (see Section 4.3.7)

4.3.9 Halt Command

Description

Immediately decelerates and halts pan-tilt movement.

Syntax

Halt all pan-tilt movement:	H<delim>
Halt pan axis movement:	HP<delim>
Halt tilt axis movement:	HT<delim>

Example

```
PP2500 *
A *
PP-2500
```

Then while the pan-tilt is moving, the host decides to stop immediately :

```
H *
```

Related Topics

- This command can be used for both the Immediate Position Execution Mode (see Section 4.3.6) and Slaved Position Execution Mode (see Section 4.3.7)

4.3.10 Monitor (Autoscan) Command

Description

Command defines and initiates repetitive monitoring (scanning) of the pan-tilt. Autoscanning is immediately terminated upon receipt of a character from the host computer, and the pan-tilt is sent to its home position.

Syntax

Initiate monitor (autoscan) in pan axis only:

```
M<pan pos 1>,<pan pos 2><delim>
```

Initiate monitor (autoscan) in both pan and tilt axes:

```
M<pan pos 1>,<pan pos 2>,<tilt pos 1>,<tilt pos 2><delim>
```

Initiate last defined monitor (autoscan) command (the default at power up is pan axis only autoscan between the pan limit positions):

```
M<delim>
```

Enable monitor (autoscan) at power up: **ME<delim>**

Disable monitor (autoscan) at power up: **MD<delim>**

Query monitor status at power up: **MQ<delim>**

Example

When executed at power up,

```
M *
```

the pan-tilt begins scanning between the minimum and maximum pan limit positions.

```
<delim>
```

terminates the scanning and homes the pan-tilt. Other monitoring command forms:

```
M-2500,100 *
```

```
M-2500,100,-800,600 *
```

```
M0,0,-300,300 *
```

Related Topics

- Limit Position Queries (see Section 4.3.4)

4.3.11 Position Presets

Description

Position preset functionality is provided for backward compatibility with legacy CCTV applications. D300 pan-tilt controller firmware version v2-12-11r2 and higher support position presets. The pan-tilt can be commanded to a position using any of the standard motion control commands of the D300 PTU. The current pan and tilt position can be stored as a numbered "preset". The PTU can then be commanded to a previously stored preset using a new "go to preset" command. Currently set motion parameters (acceleration, base rate, etc.) apply during "go to preset" commands. Preset positions are remembered when the controller is repowered.

Syntax

```
XS<index><delim> where <index> ? [0..32] "Set Preset"
```

```
XG<index><delim> where <index> ? [0..32] "Goto Preset"
```

```
XC<index><delim> where <index> ? [0..32] "Clear Preset"
```

Example

The following commands set the Pan/Tilt to position 500/400, store as preset 0, move the unit to position 600/800, and then goes back to previously stored preset 0 position.

PP500 *
TP400 *
XS0 *
PP600 *
TP800 *
XG0

4.4 Speed Control Commands & Queries

4.4.1 Speed Control & Relevant Terms

The Pan-Tilt Unit provides for precise control of axis speed and acceleration. This subsection briefly describes how speed control is performed and it introduces relevant terms.

As shown in Figure 5, *upper and lower speed limits* determine the bounds on nonstationary pan-tilt velocities. The *base (start-up) speed* specifies the velocity at which the pan-tilt axis can be started from a full stop without losing synchrony (as described in Section 3.8), and it is more a function of the motors rather than load characteristics. Due to base speed requirements and the property that motors lose torque as speed increases, acceleration is required to achieve axis speeds above the base rate. The pan-tilt controller uses trapezoidal acceleration and deceleration for speeds above the base rate and less than the maximum allowed speed. Figure 5 shows two acceleration cases. In the first, an axis accelerates up to a desired constant speed (*slew rate*), then decelerates. The second case shows the case when the unit does not have sufficient time to accelerate up to the desired slew speed before the need to decelerate to the desired position.

The pan-tilt controller provides for on-the-fly position and speed changes. If the direction is changed on-the-fly, the controller manages all deceleration, direction reversal, and acceleration to achieve the most recently specified target pan-tilt speed and acceleration rates.

Because speed, acceleration, and position are precisely controlled, you can accurately and simply predict the position attained by the pan-tilt unit in time.

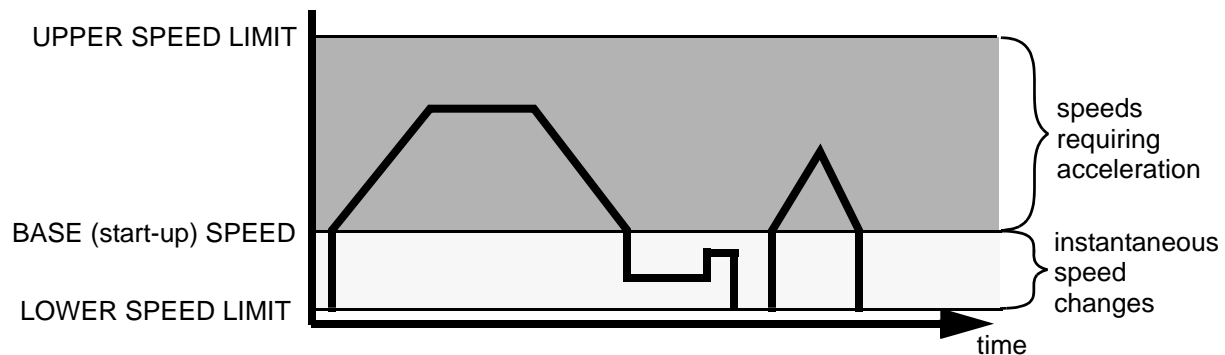

Figure 5: Axis Speed, Instantaneous Speeds, Trapezoidal Acceleration, and On-The-Fly Speed and Position Changes

4.4.2 Speed (absolute)

Description

Specify or query desired axis speed. Desired speed is specified in positions/second and it can be changed on-the-fly. The speed specifies the rate at which the pan-tilt moves to achieve position movement commands.

Desired speed commands outside the speed bounds return an error and are not executed.

Syntax

```

Query desired pan speed:      PS<delim>
Set desired pan speed:       PS<positions/sec><delim>

Query desired tilt speed:     TS<delim>
Set desired tilt speed:      TS<positions/sec><delim>

```

Example

The following commands instruct the pan axis to move to the far left, then slowly move right, and then on-the-fly it speeds up:

```

I *
PS1900 *
PP2600 *
A *
PS600 *
PP-2600 *
PS1900 *

```

Related Topics

- Position commands: See Section 4.3.1 - 4.3.2
- Position resolution (units): See Section 4.3.3
- Speed bounds: See Section 4.4.6

4.4.3 Delta Speed (relative offset)

Description

Specify desired axis speed as an offset from the current speed, or Query the current axis speed. Desired delta (offset) speed is specified in positions/second and it can be changed on-the-fly. A desired delta speed command that results in a speed outside the legal speed bounds returns an error and it is not executed.

Syntax

```

Query current pan speed:      PD<delim>
Set desired delta (offset) pan speed: PD<positions/sec><delim>

Query current tilt speed:     TD<delim>
Set desired delta (offset) tilt speed: TD<positions/sec><delim>

```

Example

The following commands instruct the pan axis to move to the far left, then slowly move right, and then on-the-fly it decreases speed by -150 positions/second, then queries the current speed:

```

I *
PS1900 *
PP2600 *
A *
PS600 *
PP-2600 *
PD-150 *
PD * Current Pan speed is 450 positions/sec

```

Related Topics

- Position commands: See Section 4.3.1 - 4.3.2
- Position resolution (units): See Section 4.3.3

- Speed bounds: See Section 4.4.6

4.4.4 Acceleration

Description

Specify or query axis acceleration and deceleration for speeds above the base speed. Acceleration is specified in positions/second².

Syntax

Query desired pan acceleration: **PA<delim>**
 Set desired pan acceleration: **PA<positions/sec²><delim>**
 Query desired tilt acceleration: **TA<delim>**
 Set desired tilt acceleration: **TA<positions/sec²><delim>**

Example

The following illustrate different rates of acceleration:

```
PA * Pan acceleration is 2000 positions/sec^2
PB * Current Pan base speed is 1000 positions/sec
PU * Maximum Pan speed is 2902 positions/sec
PP0 *
PS1900 *
PP2600 *
PA1500 *
PP0 *
```

Related Topics

- Position resolution (units): See Section 4.3.3
- Symmetric trapezoidal acceleration is used, so the rate of deceleration is equivalent to the rate of acceleration
- Acceleration cannot be changed on-the-fly since it takes several seconds to recompute the internal tables used to rapidly execute speed ramping.

4.4.5 Base (Start-Up) Speed

Description

Specify or query axis base (start-up) speed. Base speed is specified in positions/second. Defaults to 57 positions/sec.

Syntax

Query desired pan base speed: **PB<delim>**
 Set desired pan base speed: **PB<positions/sec><delim>**
 Query desired tilt base speed: **TB<delim>**
 Set desired tilt base speed: **TB<positions/sec><delim>**

Example

The following commands home the pan axis, moves it far left, changes the base rate, then moves back to home:

```
I *
PP0 *
A *
PP2600 *
PB * Current Pan base speed is 1000 positions/sec
PB1000 *
PP0 *
```

Related Topics

- Position resolution (units): See Section 4.3.3
- Acceleration: See Sections 4.4.1 and 4.4.4
- Speed bounds: See Section 4.4.6
- Changes in the base rate cannot be made on-the-fly since it takes several seconds to recompute the internal tables used to rapidly execute speed ramping.

4.4.6 Speed Bounds

Description

Set and query the upper and lower speed bounds for desired speed commands.

Syntax

```

Query upper pan speed limit:  PU<delim>
Set upper pan speed limit:   PU<positions/sec><delim>

Query lower pan speed limit:  PL<delim>
Set lower pan speed limit:   PL<positions/sec><delim>

Query upper tilt speed limit: TU<delim>
Set upper tilt speed limit:  TU<positions/sec><delim>

Query lower tilt speed limit: TL<delim>
Set lower tilt speed limit:  TL<positions/sec><delim>

```

Example

```

PU * Maximum Pan speed is 1985 positions/sec
PS3300 ! Pan speed cannot exceed 1985 positions/sec
PS1985 *
PL * Minimum Pan speed is 31 positions/sec
PL20 ! Motor speed cannot be less than 31 pos/sec
PL40 *

```

Related Topics

- Position resolution (units): See Section 4.3.3
- Changes in the upper speed limit cannot be made on-the-fly since it takes several seconds to recompute the internal tables used to rapidly execute speed ramping.

4.4.7 Speed Control Modes

Description

By default, position control commands are independent from the speed control commands. In this *independent control mode*, the commanded speed is an unsigned magnitude that determines the speed at which independently commanded positions are effected, and the execution of these speed commands do not affect the commanded desired positions themselves. This mode is appropriate for pure position control methods (when pan-tilt control is effected solely by commanding pan-tilt position) and hybrid position-velocity control methods (when pan-tilt positions and the rate at which they are achieved are both controlled).

An alternative pan-tilt control method uses a *pure velocity control mode* in which all pan-tilt control is effected by signed changes in command axis

speed. In this mode, the speed command specifies a signed velocity in which the sign determines the direction of axis movement, and the ordinal value specifies the speed of movement in this direction. In this mode, if the commanded speed is negative, the axis is automatically commanded to the minimum axis position. Conversely, if the speed command is positive, the axis is automatically commanded to the maximum axis position. A speed of zero is applied by halting the axis motion. *It is important to note that in pure velocity control mode, a speed command for a given axis effectively overrides currently executing position commands.* As a result, the speed control mode at power up is always set to independent control mode; the speed control mode is not saved as defaults that are preserved when the unit is powered back up.

These commands are available in PTU firmware versions 1.09.7 and higher.

Syntax

Query the current speed control mode: **C<delim>**
 Set to independent control mode (default): **CI<delim>**
 Set to pure velocity control mode: **CV<delim>**

Example

Put into the default independent control mode, the pan-tilt will finish at position -3000. Put in the pure velocity control mode, the pan-tilt will finish on the opposite pan side. Note that the default restore (also executed upon unit power up) restores the unit to independent control mode:

```

CI *
PP-3000 *
PS1000 *
A *
CV *
PP-3000 *
PS1000 *
DR *
PP-3000 *
PS1000 *

```

Related Topics

- Position commands: See Section 4.3.1-4.3.2
- Speed commands: See Section 4.4.2-4.4.3

4.5 Unit Commands

4.5.1 Reset Pan-Tilt Unit

Description

This command controls how, and when, the pan-tilt unit is calibrated. By default, the pan-tilt unit is configured to reset both the pan and tilt axes automatically upon power up and by issuing the reset command.

The reset mode commands are used to control the reset performed at pan-tilt power up, and to allow reset of an individual pan-tilt axis. The reset calibration allows the pan-tilt unit to determine axis coordinates, hence *a pan-tilt axis should be reset prior to issuing any axis position commands.* A pan-tilt axis that has not been calibrated has a minimum and maximum axis

position of 0 (see Section 4.3.4), hence position commands in limit enabled mode (see Section 4.3.5) will return an illegal position command feedback.

Syntax

Performs Reset calibration: **R<delim>**

Reset modes (saved in internal EEPROM for power up reset control):

Disable reset upon power up: **RD<delim>**

Reset tilt axis only: **RT<delim>**

Reset pan axis only: **RP<delim>**

Reset both pan and tilt axes upon power up: **RE<delim>**

Example

```
RT *
R *
RP *
R *
RD *
R *
RE *
R *
```

Related Topics

- A load beyond the handling capacity of the pan-tilt unit may cause the reset to fail, so load handling capability should be tested as described in Section 3.7.

4.5.2 Default Save/Restore

Description

Allows current axis settings to be saved as defaults that are preserved when the unit is powered back up. Also allows the factory defaults to be restored.

Syntax

Save current settings as defaults: **DS<delim>**

Restore stored defaults: **DR<delim>**

Restore factory defaults: **DF<delim>**

Related Topics

- Defaults are saved in EEPROM which have a lifetime limit on the number of writes before memory failure. Though it is unlikely that these failure limits will be reached, excessive saving of current defaults should be avoided when possible.

4.5.3 Echo Query/Enable/Disable

Description

Sets of queries whether the pan-tilt controller echoes incoming commands from the host.

Syntax

Query current echo mode: **E<delim>**

Enable host command echoing: **EE<delim>**

Disable host command echoing: **ED<delim>**

Example

```

PP * 22
ED *
<pp entered again, but not echoed>* 22

```

4.5.4 Feedback Verbose/Terse/Off

Description

Command and query the ASCII feedback returned by PTU commands.

Syntax

```

Enable verbose ASCII feedback:      FV<delim>
Enable terse ASCII feedback:       FT<delim>
Query ASCII feedback mode:         F<delim>

```

Example

```

FV *
PP * Current pan position is 0
FT *
PP * 0
F * ASCII terse mode

```

4.5.5 Controller Firmware Version Query

Description

Query specifies the version and copyrights for the pan-tilt controller firmware.

Syntax

```
v<delim>
```

Example

```
V * Pan-Tilt Controller v2.12.1d1(C14/E), (C)2003 Directed Perception, Inc., All
Rights Reserved
```

4.5.6 Outside Supply Voltage and Controller Temperature Query

Description

The pan-tilt controller includes sensors for the internal temperature and the input voltage supplied to the pan-tilt. This query measures and prints the controller temperature and input supply voltage.

Syntax

```
O<delim>
```

Example

```
O * Input 30 VDC @ 86 degF
```

4.6 Power Control Commands & Queries

A key advantage of the constant current motor control drivers used in the Pan-Tilt Controller is that it allows the current consumed by the pan-tilt unit to be controlled via simple unit commands. These capabilities are useful for battery powered operation (see Section 7), reducing unit heat generation, and extending the rated life of the motor driver circuitry.

4.6.1 Stationary Power Mode

Description

Set and query the current level applied to axis motors when not in-transit.

Syntax

Query pan hold power mode:	PH<delim>
Regular pan hold power mode:	PHR<delim>
Low pan hold power mode:	PHL<delim>
Off pan hold power mode:	PHO<delim>
Query tilt hold power mode:	TH<delim>
Regular tilt hold power mode:	THR<delim>
Low tilt hold power mode:	THL<delim>
Off tilt hold power mode:	THO<delim>

Example

```
PH * Pan in REGULAR hold power mode
PHL *
PH * Pan in LOW hold power mode
```

Related Topics

- Because holding torque for steppers is significantly greater than generated dynamic torque, it is highly recommended that Low Hold Power Mode be used when appropriate for your load. Regular hold power is intended to be used for brief periods when very high holding torque may be required; this requirement is rare. Regular hold power mode should be avoided or used sparingly, as its use for long periods of time can lead to significant motor and controller heating (depending on ambient temperature).
- When using Off Hold Power Mode, fully test that your load does not backdrive the unit when stationary. Backdriving will cause the controller to lose track of pan-tilt position, and this requires that the unit be reset (see Section 4.5.1). Backdriving is more likely on the tilt axis which has higher torque applied to it by the load.

4.6.2 In-Motion Power Mode

Description

Set and query the current level applied to axis motors when in-motion (in-transit).

Syntax

Query pan move power mode:	PM<delim>
High pan move power mode:	PMH<delim>
Regular move hold power mode:	PMR<delim>
Low pan move power mode:	PML<delim>
Query tilt move power mode:	TM<delim>
High tilt move power mode:	TMH<delim>
Regular tilt move power mode:	TMR<delim>
Low tilt move power mode:	TML<delim>

Example

```

PM * Pan in REGULAR move power mode
PML *
PM * Pan in LOW move power mode

```

Related Topics

- It is not recommended that an axis be in transit more than 20% of the time when in High Move Power Mode (*i.e.*, a 20% duty cycle).

4.7 Host Serial Port and Control

As was described in Section 3, default host computer communications with the pan-tilt controller is 9600 baud. Host computer communications can be via RS-232, or as described in Section 7 it can be via the built-in RS-485.

Host serial port baud rates can be modified from the default. Also, a character delay may be specified for applications that cannot consume pan-tilt output rapidly enough.

4.7.1 Configuring Host Serial Port Baud and Communications

Description

Command specifies the baud rate for the host serial port RS232/RS485 communications with the pan-tilt controller. Only baud rate can be modified. The pan-tilt controller RS232/485 communications always use 1 start and stop bit, 8 data bits and no handshaking. The command also allows a transmission delay to be placed between bytes output by the pan-tilt controller.

The host serial port command in this Section 4.7.1 is only available when the controller is not networked (*i.e.*, the unit ID is the default of 0). ***When the controller is networked (i.e., unit ID is greater than 0), the host serial port communications rate is automatically set to the default and it cannot be modified by this command:*** the default is 9600 baud, 8 data bits, 1 start and stop bit, no parity, no handshaking, and no byte transmission delay. This ensures that networked controllers will *always* communicate at the same baud rate, and that higher data rates will not unduly burden pan-tilt controller processors.

Syntax

```
@(<baud>,<byte delay in msec>,<startup default>)<delim>
```

where:

<baud> may be 600, 1200, 2400, 4800, 9600, 19200 or 38400 bits/sec

<byte delay in msec> is the time in milliseconds the pan-tilt controller waits between transmitting output data. If no delay is desired, use a parameter of 0, otherwise, the delay may vary from 10 ms to 1000 ms.

<startup default> If T, <baud> and <byte delay in msec> are applied at power up; otherwise, the power up default is 9600 baud with no byte transmission delay.

Example

The following command sets the host serial port RS232/RS485 to a baud rate of 38,400 bits/second (8 data bits per byte, no parity, no handshaking), no delay in controller outbound byte transmission, and the power up baud rate is the system default of 9600 baud.

```
@(38400,0,F) *
```

The following command sets the host serial port RS232/RS485 to a baud rate of 19,200 bits/second (8 data bits per byte, no parity, no handshaking), a 30ms delay between bytes output from the pan-tilt controller, and the power up baud rate overrides the default and is set at 19,200 baud.

```
@(19200,30,T) *
```

Related Topics

- To wire the host port serial RS232 communications: See Section 3.4
- To wire the host port serial RS485 communications: See Section 7.2
- To set the pan-tilt controller unit ID: See Section 7.3.1

4.8 Step Modes

4.8.1 Configuring Step Mode

Description

The default motion resolution of the D300 controller is half step mode. Firmware versions 2.12.8 and higher added microstepping in quarter and eighth steps. Microstepping provides much quieter operation and smoother motion at slow speeds. In addition, the microstepping increases the effective resolution of the pan-tilt unit.

Firmware versions 2.13.0 and higher added autostep electronic gearing. The controller will automatically select the correct step mode based on the pan-tilt's current speed, and process all units as though the unit were in eighth step mode while allowing the unit to move at the higher speeds of half step.

Syntax

```
W<axis><resolution> where
  <axis> ::= T | P
  <resolution> ::= F | H | Q | E | A
for Full, Half, Quarter, Eighth and Auto step
resolution.
```

Example

The following command puts the tilt axis into eighth step resolution and recalibrates the tilt axis, which returns success (*).

```
WTE *
```

Known Issues

- Autostep mode is only supported in firmware versions v2.13.0 and higher. This firmware supports querying the microstep mode with the "W<axis><delimiter>" command.
- Microstepping decreases the pull-out torque of the motor.

5 SPECIAL CONFIGURATIONS

5.1 High-Speed Operation

This section discusses how to improve high speed pan-tilt unit performance for your load. The primary factors that affect high speed operation are:

- Load weight, weight distribution and dynamics
- Desired upper speed limit (see Section 4.4.6)
- Rate of acceleration (see Section 4.4.4)
- The base (start-up) speed (see Section 4.4.5)
- The voltage of the source power supply. Use of the highest available voltage in the range 9-30VDC significantly improves axis speed and acceleration performance.
- The in-motion power mode (see Section 4.6.2) and stationary power mode (see Section 4.6.1).
- Multi-axis dynamics. Simultaneously moving the tilt and pan axes affects the forces exerted on the pan axis.

High speed operation tests should always begin on each axis in isolation. When the best performance for each axis in isolation is understood, high speed operation of simultaneous pan-tilt axis movements can be performed.

An example configuration string for high speed operations is:

```
PA9000 TA9000 DS
```

5.2 High-Payload Operation

This section discusses how to improve high payload weight operation of the pan-tilt. The primary factors affecting payload capacity is the tilt axis, as it forms a mechanical lever which is an efficient force multiplier. The primary means to increase payload capacity are:

- Configure the pan-tilt controller for increased motor current and torque. An example configuration string to increase payload capacity is:

```
DF PA1000 TA1000 PB57 TB57 PMR TMR DS
```

 If your move duty cycle is less than 20%, you can alternatively use the highest move current settings and regular hold power settings of **PMH TMH PHR THR** .
- Move the payload center of gravity closer to the tilt axis
- Use a higher voltage power source in the range 9-30VDC
- Determine if the payload can be modified to lighten it.

5.3 Battery-Powered Operation

The Pan-Tilt Unit has been designed for battery powered operation. Battery powered applications need to conserve power when possible. The pan-tilt unit has commands to control pan-tilt motor power consumption while in transit and when stationary (see Sections 4.6.1 and 4.6.2). Careful testing can be used to determine the lowest power modes that assure your load can be moved and held without losing synchrony (see Section 3.8).

6 PTU OPTIONS

6.1 EIO Option: Expansion Serial Ports and Control

For OEM applications, internal D300 wiring can be brought out on FFC (flat flex connectors) to provide for additional control signals. For example, other serial devices attached or proximal to the pan-tilt may require other RS232 serial ports. Please contact Directed Perception for additional information on these custom configurations.

7 NETWORKING

The PTU lets you connect up to 127 PTUs to a single host computer port. Your host computer can then address each PTU on the network as though the PTU were the only unit attached to the host. In this way, it is simple to migrate existing code developed for a single PTU to a network of PTUs controlled by a single host computer.

This section describes the basic installation and setup steps required to network your pan-tilt units.

7.1 Basic Networking Setup Steps

The steps in networking your PTUs to your host computer are:

1. Sketch out the physical placement of your PTUs and host computer.
2. Assign a unique network ID number to each PTU.
3. Connect the PTUs and host computer to the PTU network.
4. Test the configuration by addressing each PTU by its unit ID and commanding and querying its attached pan-tilt unit.

7.2 PTU Network Connections

Figure 6 illustrates how PTUs can be networked and connected to a host computer via its RS-232 port. Each PTU has a built-in RS-232 to RS-485 converter, and the host computer can be connected to the RS-485 controller network by simply connecting to the RS-232 connector on a PTU. The PTUs are then connected together via an RS-485 multi-drop network (full duplex).

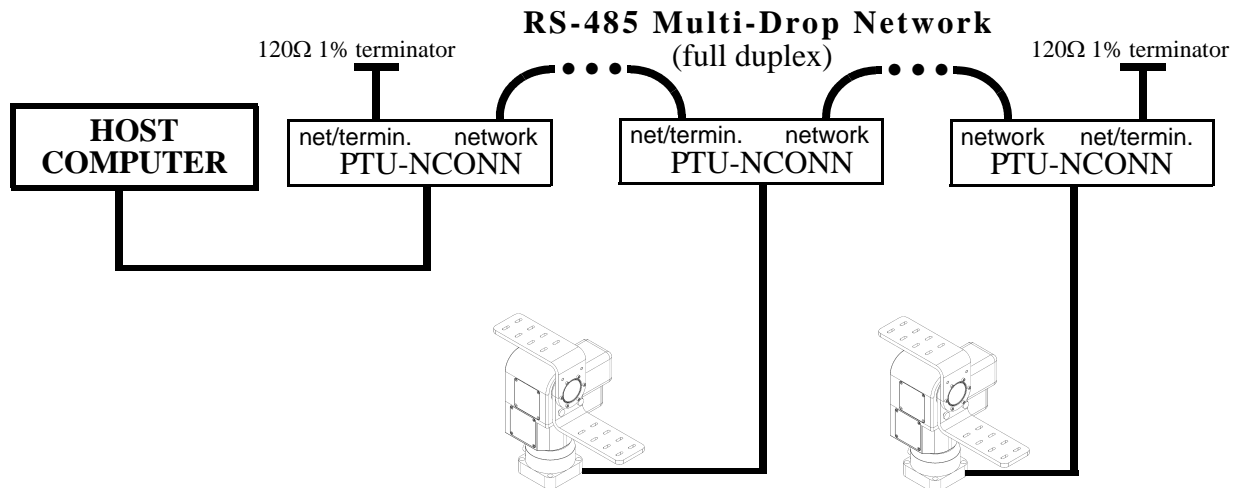

Figure 6: Making PTU Network Connections

Several issues are important to note when you make your own data cables. First, use a good quality cable. Though a good quality telephone cord cable can be used, use of a twisted pair cable is highly recommended. A twisted pair whose impedance is about 100Ω is typically used for longer RS-485 runs. The twisted pair provides good noise immunity owing to the relative signals used by the RS-485 standard.

For some applications, the host computer may directly provide RS-485 full-duplex I/O. In this case, you may directly connect your host computer to the PTU network. For computers with only RS-232, RS-485 connections may be simply made using an external RS-232 to RS-485 converter. Directed Perception has tested/qualified two converters: ATEN IC-485S and Moxa A50 which both require a flipped RJ-12 connector (such as a standard phone cord). It is important to note that the network should be terminated using 120Ω 1% resistors to protect against signal ringing on the network. Termination is achieved by placing the resistors between the RS-485 Transmit+/Transmit- and Receive+/Receive- wires at each end of the multidrop wiring network.

7.3 PTU Network Software Commands

This section describes the pan-tilt command set used to configure, set and query the network configuration of your PTU controllers.

7.3.1 Unit Network ID

Description

Specify or query the PTU controller network unit ID number. By default, the PTU unit ID is set to zero which indicates the PTU controller is not networked, and the PTU controller is in the default interactive communications mode. When assigning a unit ID number to a controller, the unit ID number should be unique, the controller should be the only PTU controller attached to the host computer or terminal (otherwise other controllers may be set to the same unit ID number). A unit ID of zero may be used to put a PTU controller back in interactive (non-networked) mode.

Syntax

```

Query current PTU network unit ID:      U<delim>
Set PTU to interactive mode (non-networked): U0<delim>
Set PTU network unit ID:                U<unit_ID><delim>
where 1 ≤ <unit_ID> ≤ 127

```

Example

The following queries a PTU unit ID, then sets and stores the unit ID configuration so that upon power-up the new unit ID will be used.

```

U * Unit ID is 0
U1 *
U * Unit ID is 1
U1 *
DS *

```

Related Topics

- Unit Select/Deselect: See Section 7.3.2.

7.3.2 Unit Select/Deselect

Description

Command is used to select the PTU to be controlled. A PTU will execute incoming host computer commands only when the preceding unit_ID selected by the host is (a) equal to the PTU's assign unit ID, or, (b) equal to 0. A host computer can broadcast instructions to be executed by all PTUs using unit_ID=0. Only one PTU can provide feedback to the host computer at a time. A PTU provides feedback to the host computer only when the host computer has selected its unit ID. A PTU buffers its outgoing data until the host computer polls it -- the current PTU buffer size is about 100 bytes.

Syntax

```

Select a PTU for bi-directional data:      _<unit_ID><delim>
Broadcast to all networked PTUs:          _0<delim>
where 0 ≤ <unit_ID> ≤ 127

```

Example

```

_1
pp300 *
_0
pp300
_1
*

```

Related Topics

- Unit Network ID: See Section 7.3.1.

A.3 D300 Base Connector Wiring

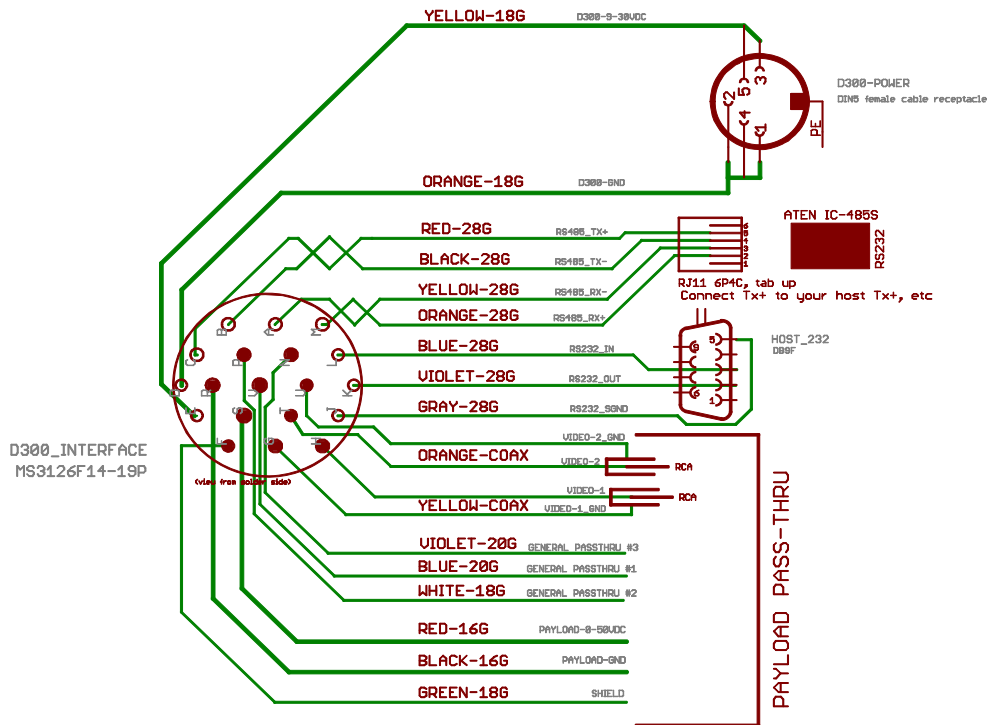

COLOR CODING FOR TecNec PN# TN-CCQAM

DIRECTED PERCEPTION, INC.	
1485 Rollins Road, Burlingame, CA 94010 * (650)342-9399, F:(650)342-9199	
TITLE: D300AC-CAB-25B0 wiring diagram	
Document Number:	REV: 1.1A
Date: 11/17/2006 03:40:10p	Sheet: 1/1
*** CONFIDENTIAL ***	By: PK

A.4 D300 Payload Wiring PL01

D300 Payload PL01 Pinout (rev 1.3)
10/23/2006

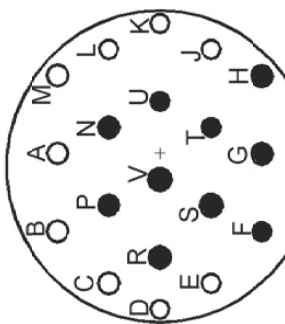

B	CHA 232 TX	A	CHA 232 RX	M	232 SGND
C	CHB 232 RX	P	GENERAL PASSTHRU #2	N	GENERAL PASSTHRU #3
D	CHB 232 TX	R	PAYLOAD GND	V	GENERAL PASSTHRU #1
E	CHB 232 OTR	S	PAYLOAD DC 0-50VDC	T	VIDEO-2
F	SHIELD	G	VIDEO-1 GND	H	VIDEO-1
				J	TTL OP2
				L	CHA TTL TX
				U	VIDEO-2 GND
				K	CHA TTL RX

BLACK designates D300 controller signals

(view from solder side)
D300_PAYLOAD
MIL-C-26482

RED (bold) denotes pass-thru from D300 input connector

· {R, S} are rated 3A

· {F, G, H, N, P, T, U, V} are rated 1A

CAUTION: DO NOT EXCEED MAXIMUM RATED PASS-THRU AMPERAGES. FUSE PAYLOADS AT RATED TRIP VALUES.

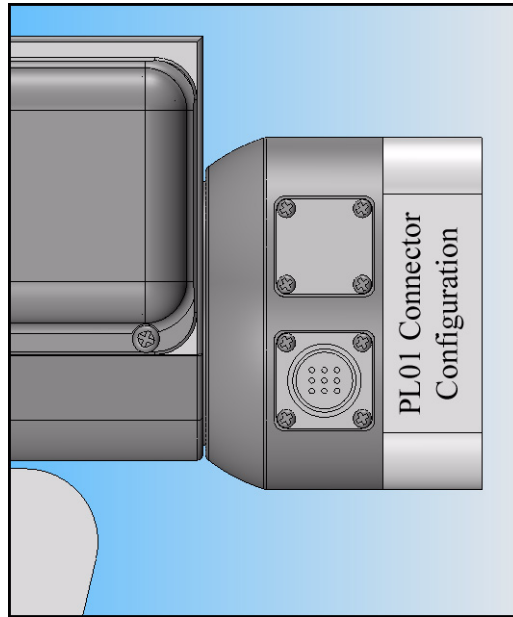

A.5 D300 Payload Wiring PL02

D300 Payload PL02 Pinout (rev 1.1)
10/23/2006

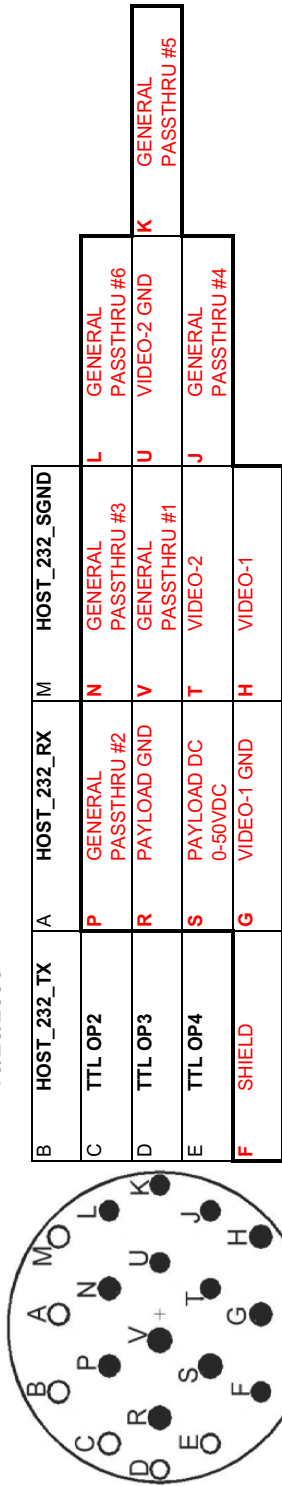

(view from solder side)

D300_PAYLOAD
MIL-C-26482

B	HOST_232_TX	A	HOST_232_RX	M	HOST_232_SGND
C	TTL OP2	P	GENERAL PASSTHRU #2	N	GENERAL PASSTHRU #3
D	TTL OP3	R	PAYLOAD GND	V	GENERAL PASSTHRU #1
E	TTL OP4	S	PAYLOAD DC 0-50VDC	T	VIDEO-2
F	SHIELD	G	VIDEO-1 GND	H	VIDEO-1
				L	GENERAL PASSTHRU #6
				U	GENERAL VIDEO-2 GND
				J	GENERAL PASSTHRU #4
				K	GENERAL PASSTHRU #5

BLACK designates D300 controller signals
· {A, B, M} are RS232 level signals

RED (**bold**) denotes pass-thru from D300 input connector

· {R, S} are rated 3A

· {F, G, H, J, K, L, N, P, T, U, V} are rated 1A

CAUTION: DO NOT EXCEED MAXIMUM RATED PASS-THRU AMPERAGES. FUSE PAYLOADS AT RATED TRIP VALUES.

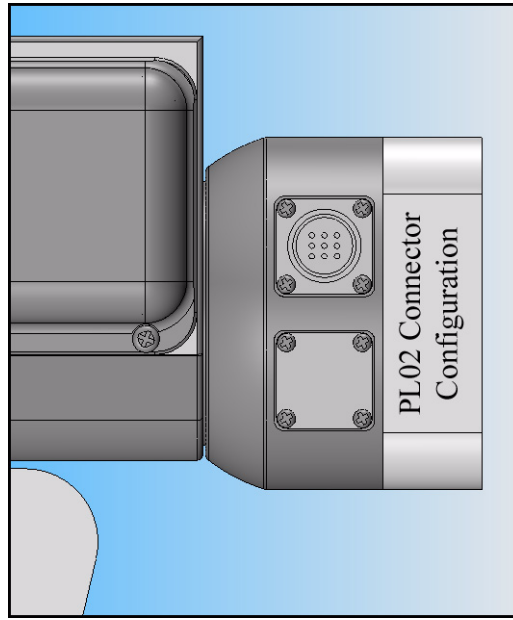

A.6 D300 Payload Mounting

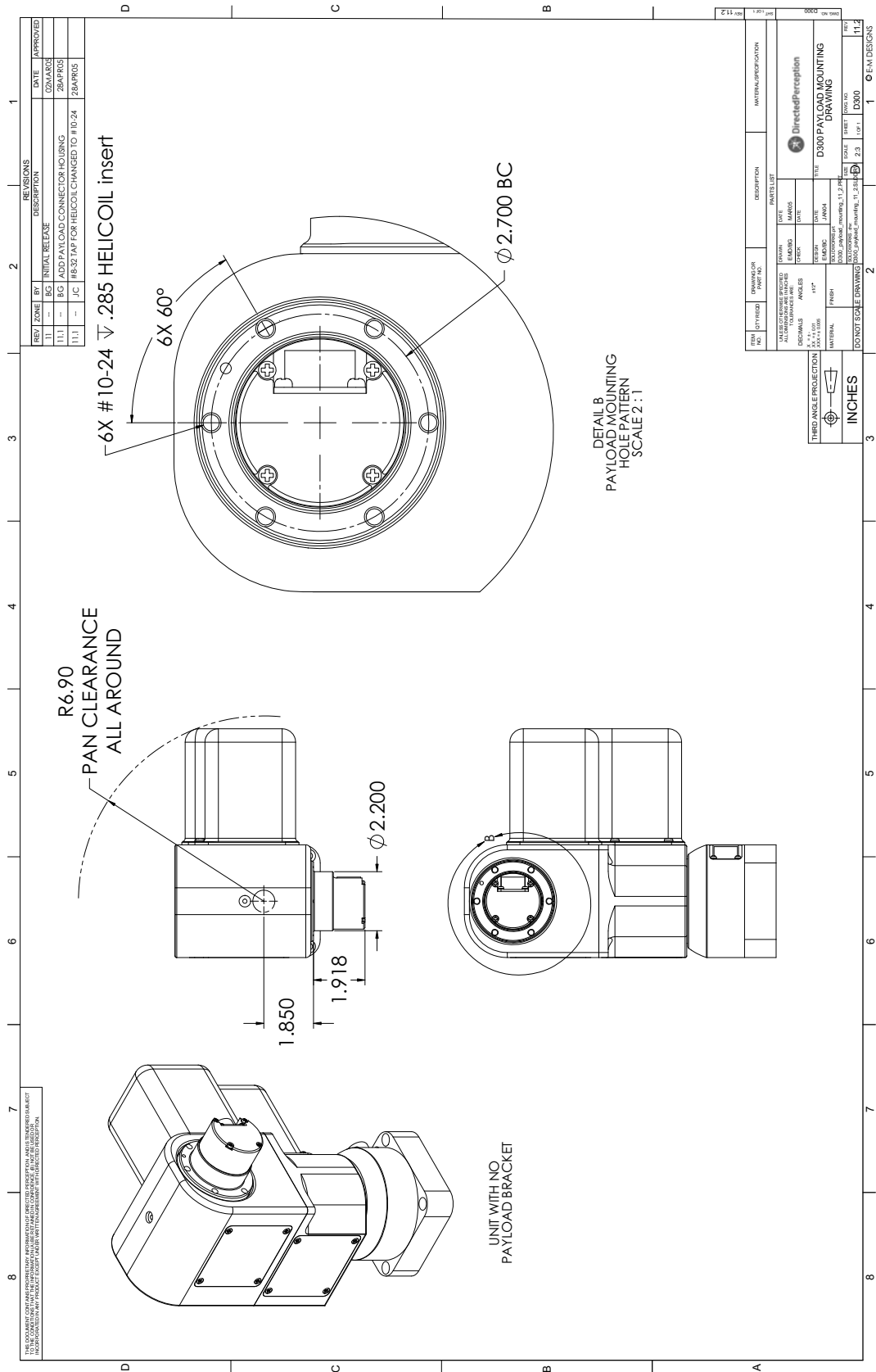

REGULATORY INFORMATION

Electromagnetic Interference (EMI) is any signal or emission, radiated in free space or conducted along power or signal leads that endangers the function of a radio navigation or other safety service or seriously degrades, obstructs, or repeatedly interrupts a licensed radio communications service.

Class A

Class A equipment has been tested and found to comply with the limits for a Class A digital device, pursuant to Part 15 of the FCC Rules. These limits are designed to provide reasonable protection against harmful interference in a commercial environment. This equipment generates, uses and can radiate radio frequency energy and, if not installed and used in accordance with the instructions, may cause harmful interference to radio communications. However, there is no guarantee that interference will not occur in a particular installation. Operation of this equipment in a residential area is likely to cause harmful interference, in which case the user will be required to correct the interference at his/her own expense.

Class B

Class B equipment has been tested and found to comply with the limits for a Class B digital device, pursuant to Part 15 of the FCC Rules. These limits are designed to provide reasonable protection against harmful interference in a residential installation. This equipment generates, uses and can radiate radio frequency energy and, if not installed and used in accordance with the instructions, may cause harmful interference to radio communications. However, there is no guarantee that interference will not occur in a particular installation. If this equipment does cause harmful interference to radio or television reception, which can be determined by turning the equipment off and on, the user is encouraged to try to correct the interference by one or more of the following measures:

- Reorient or relocate the receiving antenna.
- Increase the separation between the equipment and receiver.
- Connect the equipment into an outlet on a circuit different from that to which the receiver is connected.
- Establish good grounding to the base connector.
- Consult the dealer or an experienced radio/TV technician for help.

Caution: Changes or modifications of this equipment not expressly approved by manufacturer could result in violation of Part 15 of the Federal Communication Commission's rules. The FCC has prepared the following booklet: "How to Identify and Resolve Radio-TV Interference Problems." It is available from the US Government Printing Office, Washington DC, 20402. Stock Number 004-00-00345-4.

FCC Notice

According to 47CFR, Parts 2 and 15, Subpart B Class A:

This device complies with FCC Part 15, Subpart B Class A of the FCC Rules. Operation is subject to the following two conditions: (1) This device may not cause harmful interference, (2) This device must accept any interference received including interference that may cause undesired operations.

LIMITED WARRANTY

Directed Perception, Inc. warrants this product against defects in material or workmanship, as follows:

For a period of one year from date of purchase, Directed Perception, Inc. will repair the defective product and provide new or rebuilt replacements at no charge. Warranty repairs require the issuance of a repair authorization number from Directed Perception prior to the return of merchandise, and the buyer assumes responsibility for freight charges.

After the one year period, the purchaser must pay for all parts, labor and freight.

This warranty does not cover any damage due to accident, misuse, abuse or negligence. You should retain your original bill of sale as evidence of the date of purchase.

REPAIR OR REPLACEMENT AS PROVIDED UNDER THIS WARRANTY IS THE EXCLUSIVE REMEDY OF THE PURCHASER. DIRECTED PERCEPTION SHALL NOT BE LIABLE FOR ANY INCIDENTAL OR CONSEQUENTIAL DAMAGES FOR BREACH OF ANY EXPRESS OR IMPLIED WARRANTY ON THIS PRODUCT, EXCEPT TO THE EXTENT PROHIBITED BY APPLICABLE LAW, ANY IMPLIED WARRANTY OF MERCHANTABILITY OR FITNESS FOR A PARTICULAR PURPOSE ON THIS PRODUCT IS LIMITED IN DURATION TO THE DURATION OF THIS WARRANTY.

Some states do not allow the exclusion or limitation of incidental or consequential damages, or allow limitations on how long an implied warranty lasts, so the above limitations or exclusion may not apply to you. This warranty gives you specific legal rights, and you may also have other rights which vary from state to state.